

9761019S  
(ON ANIMATION) 台架組立図

版数 REV.	年月日 DATE	DCN NO.	変更内容 DESCRIPTION	製図 DR.	担当 CHK.	査閲 APPD.	承認 APPD.
2	10.Nov.2005	058570	CHANGE TO BILINGUAL	---	Y.TAKAGI	A.TA90	Y.KUBOTA
3	10.Apr.2006	059841	CORRECT AN ERROR, OTHER	---	Y.TAKAGI	R. Sago	J. Kubota

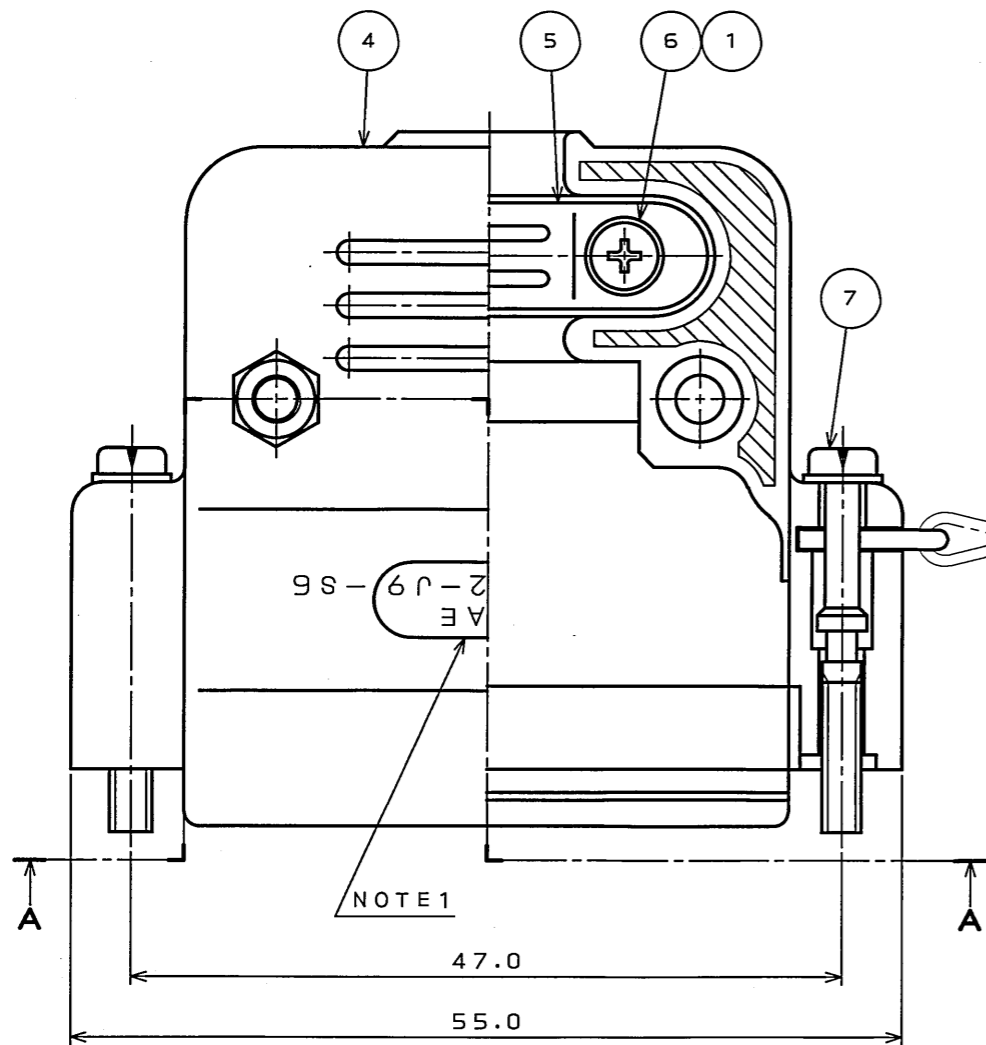

NOTE 2  
DB※-25\*  
FIXED CONNECTOR (REF.)  
コネクタ適用例 (参考)

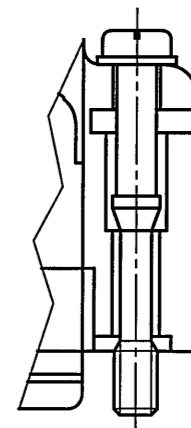
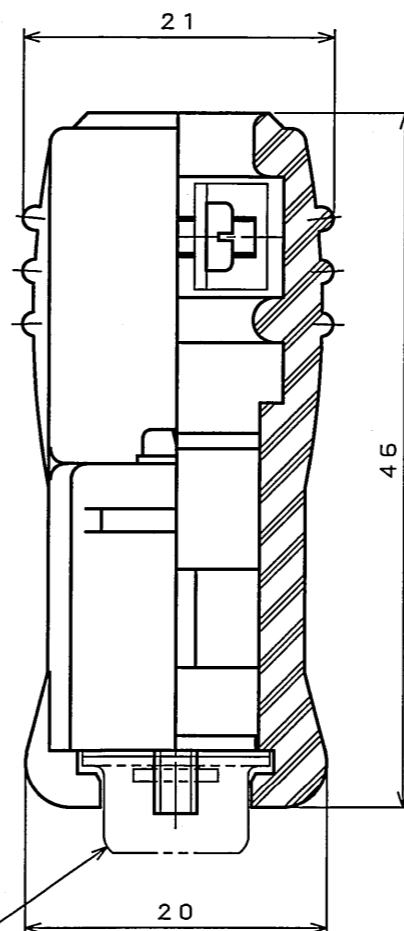

ANOTHER FORM OF SCREW LOCK  
嵌合固定ねじ別途形状

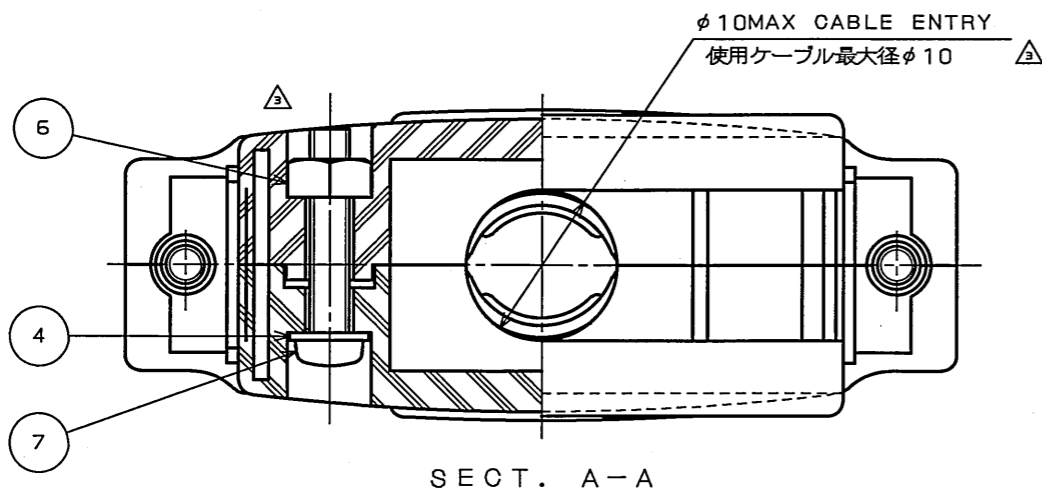

注 1. 図示の位置に社名及び品名略称を表示する。  
2. ダストキャップ取付ヒモ取付例。  
NOTE 1. MARK THE COMPANY NAME AND ABBREVIATED PART NUMBER AT THE LOCATION SHOWN IN THE DRAWING.  
2. EXAMPLE OF DUST GAP MOUNTING CORD.

符号 NO.	名称 DESCRIPTION	個数 QTY.	材料 MATERIAL	仕上 FINISH	備考 REMARKS
7	SCREW LOCK ASSY	2	STEEL	HEXAVALENT CHROMIUM FREE CHROMATE (TRIVALENT CHROMATE TREATMENT) ON ELECTROPLATED ZINC	# 4-40
6	CROSS PAN HEAD SCREW	2	STEEL	HEXAVALENT CHROMIUM FREE CHROMATE (TRIVALENT CHROMATE TREATMENT) ON ELECTROPLATED ZINC	M2.6×7
5	CLAMP SADDLE	2	STEEL	HEXAVALENT CHROMIUM FREE CHROMATE (TRIVALENT CHROMATE TREATMENT) ON ELECTROPLATED ZINC	
4	MAIN HOOD	2	ABS RESIN	(COLOR: LIGHT GREY) △	
3	HEXAGON NUT	2	COPPER ALLOY △	HEXAVALENT CHROMIUM FREE CHROMATE (TRIVALENT CHROMATE TREATMENT) ON ELECTROPLATED ZINC	M2.6
2	CROSS PAN HEAD SCREW	2	STEEL	HEXAVALENT CHROMIUM FREE CHROMATE (TRIVALENT CHROMATE TREATMENT) ON ELECTROPLATED ZINC	M2.6×14
1	SPRING WASHER	4	STEEL	HEXAVALENT CHROMIUM FREE CHROMATE (TRIVALENT CHROMATE TREATMENT) ON ELECTROPLATED ZINC	M2.6

仕様書 (SPECIFICATION)	第1版 (ORIGINAL DATE) 15.Sep.2005	尺度 (SCALE) 2:1	シリーズ (SERIES) D-sub	日本航空電子工業株式会社 JAPAN AVIATION ELECTRONICS INDUSTRY, LTD. 図面番号 (DRAWING NO.) SJ101946
公差 (GENERAL TOLERANCE)	製図 DR.	名称 (TITLE) DB-C2-J9-S6R		
寸法 (DIMENSION)	担当 CHK. Y.TAKAGI	質量 (MASS)		
角度 (ANGLES)	査閲 APPD. 承認 APPD. Y.KUBOTA	Reference		

DOF-0-212F(05.08)

